



Premium Polipasto Eléctrico de Cadena DEH / Premium Electric Chain Hoist DEH

Características

- » Construcción robusta.
- » Adecuado para una gran variedad de aplicaciones industriales.
- » Gancho de carga giratorio con pestillo de seguridad.
- » Fácil desmontaje para el mantenimiento.
- » Sistema de control con relé SIEMENS / EATON.
- » Equipado con cadena de carga RUD®.
- » La transmisión permanentemente lubricada, asegura un funcionamiento suave y silencioso.
- » Se suministra con interruptor de control, cable de alimentación y contenedor de cadena.
- » Cumple con la Directiva de Máquinas 2006/42/CE. Se suministra con certificado de pruebas, declaración de conformidad CE e instrucciones de funcionamiento.

Features

- » Robust housing.
- » Suitable for a wide range of industrial applications.
- » Swivel load hook with safety latch.
- » Easy to disassemble for maintenance purposes.
- » Control system with SIEMENS / EATON relays.
- » Equipped with RUD® load chain.
- » Permanently lubricated transmission, ensures smooth and quiet operation.
- » Supplied with control switch, power cable and chain container.
- » Complies with the Machinery Directive 2006/42/EC. Supplied with test certificate, CE declaration of conformity and operating instructions.



Especificaciones / Specifications							
Código de artículo	Capacidad	Velocidad de elevación	Cadena de carga	N.º de ramales	Consumo de energía	Peso neto	Peso extra
Article code	Capacity	Lifting speed	Load chain	Chain falls	Power output	Net weight	Extra weight
	ton	m/min	Øxmm		kW	kg	kg/m
DH.0.DEH.001253	NEW 0.125	8/2	4 x 12	1	0.4/0.1	22	0.4
DH.0.DEH.002503	0.25	8/2	4 x 12	1	0.4/0.1	22	0.4
DH.0.DEH.00503	0.5	8/2	5 x 15	1	0.72/0.18	33	0.7
DH.0.DEH.01003	1	8/2	7.1 x 21	1	1.6/0.4	53	1.1
DH.0.DEH.02003	2	4/1	7.1 x 21	2	1.6/0.4	58	2.2

Especificaciones / Specifications	
Voltaje / Operating voltage	400-440V / 50Hz / 3Ph (con carro eléctrico solo 400V / with electric trolley only 400V)
Velocidad de elevación / Lifting speed	Doble velocidad / Double speed
Cadena de carga / Load chain	Cadena de carga según EN 818-7-DAT/DT / Load chain according to EN 818-7-DAT/DT
Cable de control / Control cable	Estándar ≈6 metros / Standard ≈6 meter
Cable de energía / Power cable	≈1 metro sin enchufe / ≈1 meter without plug
Protección de la carcasa / Housing protection	IP 55
Protección de control / Control protection	IP 65
Clasificación / Classification	M5/2m (ISO/FEM)
Ciclo de trabajo / Arranques por hora / Duty cycle / Starts per hour	40% / 240
Clase de aislamiento / Insulation class	F
Temperatura de funcionamiento / Operating temperature	-10°C - +40°C
Tipo de carga / Load type	Mercancías, no se pueden utilizar para levantar personas / Goods, may not be used to lift people

Protección / Protection	
Interruptor de control / Control switch	24V interruptor con botón de parada de emergencia / 24V pendant control switch with emergency stop button
Protección de sobrecarga / Overload protection	Embrague de deslizamiento ajustable externamente / Externally adjustable slip clutch
Freno / Brake	Freno de presión de resorte electromagnético, sostiene la carga en caso de falla de energía / Electromagnetic spring pressure brake, holds the load in the event of power failure
Interruptor de límite / Limit switch	Interruptor de límite superior e inferior electromecánico / Electro-mechanical upper and lower limit switch
Protección térmica / Thermal protection	Protegido por sensor de calor / Protected through heat sensor



Premium Electrische Kettingtakel DEH / Premium Electric Chain Hoist DEH



Watch the product video!

** click on the link **



Nederlands

<https://youtu.be/zyZp5x0Ogd8>



English

<https://youtu.be/PmDD7nsrIGw>



Deutsch

<https://youtu.be/hD-nbCQm3P8>



Français

<https://youtu.be/JInvP16ODNw>



Español

<https://youtu.be/00VBnFyTmB0>



Italiano

<https://youtu.be/Yp41sYjcEyw>



Dansk

<https://youtu.be/f1ZN2H3hfcc>



Suomalainen

<https://youtu.be/pGAGfRgnhuk>



Premium Polipasto Eléctrico de Cadena DEH / Premium Electric Chain Hoist DEH



DH.0.DED



DH.0.DEY

Características

- » Polipasto de cadena eléctrico montado en un carro (eléctrico) de altura baja.
- » Carro equipado con ruedas de apoyo de equilibrio para una movilidad suave. Los soportes de seguridad sirven como protección ante caídas, roturas e impactos. Además, equipado con protección anti-inclinación.
- » Lubricado permanentemente, las ruedas montadas con rodamientos de bolas permiten un movimiento suave.
- » Adecuado para la mayoría de las vigas I y H.

Features

- » Electric chain hoist mounted on low headroom (electric) trolley.
- » Balance support wheels enable smooth travelling along the beam.
- » Safety bars serve as fall-, breaking- and impact protection. Additionally equipped with tilting protection.
- » Permanently lubricated, ball bearing mounted wheels allow for smooth traversing.
- » Suitable for most I- and H-beam profiles.

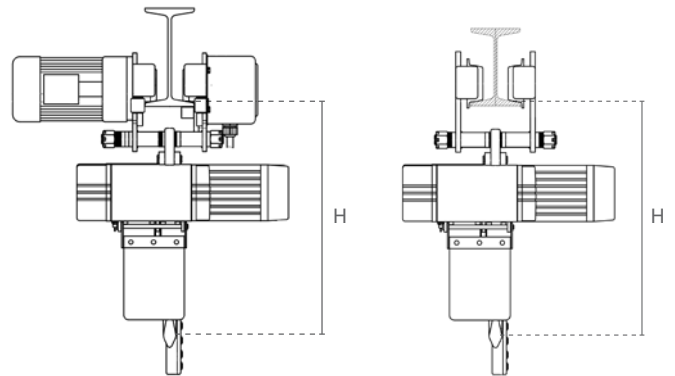

Especificaciones / Specifications						
Código de artículo	Capacidad	Velocidad de conducción	Poder del carro	Amplitud de la viga	Peso neto	Altura mín. (H)
Article code	Capacity	Traversing speed	Power output trolley	Beam width	Net weight	Min. height (H)
	ton	m/min	kW	mm	kg	mm
DH.0.DED.001253	0.125	20/6.7	0.2/0.07	74-300	53	365
DH.0.DED.002503	0.25	20/6.7	0.2/0.07	74-300	53	365
DH.0.DED.00503	0.5	20/6.7	0.2/0.07	74-300	66	445
DH.0.DED.01003	1	20/6.7	0.2/0.07	74-300	86	515
DH.0.DED.02003	2	20/6.7	0.4/0.13	74-300	98	640

Especificaciones / Specifications				
Código de artículo	Capacidad	Amplitud de la viga	Peso neto	Altura mín. (H)
Article code	Capacity	Beam width	Net weight	Min. height (H)
	ton	mm	kg	mm
DH.0.DEY.001253	0.125	74-300	44	365
DH.0.DEY.002503	0.25	74-300	44	365
DH.0.DEY.00503	0.5	74-300	55	445
DH.0.DEY.01003	1	74-300	75	515
DH.0.DEY.02003	2	74-300	80	640



Premium Polipasto Eléctrico de Cadena DEH / Premium Electric Chain Hoist DEH



Premium Polipasto Eléctrico de Cadena DEH / Premium Electric Chain Hoist DEH

Relés fácilmente intercambiables montados en base de acero / Easily exchangeable relays mounted on a steel plate

NEW 2022

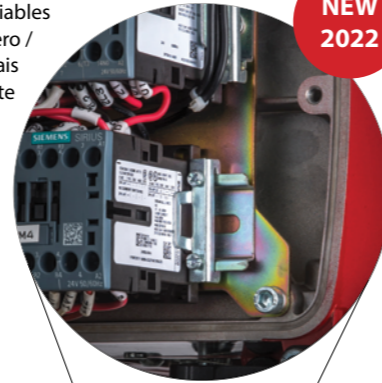

Relés de confianza / Reliable relays

- EATON
125 kg
250 kg
- SIEMENS
500 kg
1000 kg
2000 kg

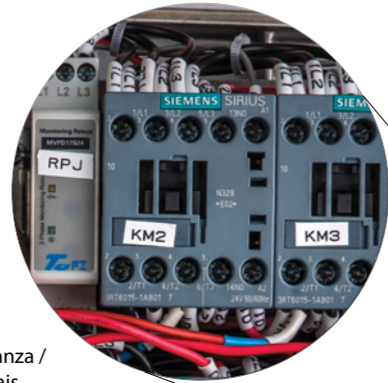

Embrague deslizante ajustable y de fácil acceso / Easily reachable and adjustable slip clutch



Cadena de carga RUD® / RUD® load chain



2da generación / 2nd generation -2022-

NEW 2022



Conexiones fáciles Plug&Play / Easy plug&play connections

NEW 2022



Guía de cadena fácilmente accesible para mantenimiento / Chain guide easily accessible for maintenance purposes

NEW 2022



Mando ergonómico actualizado / Updated ergonomic control



Micro final de carrera arriba y abajo / Upper and lower limit micro switch

NEW 2022



Tope de cadena duradero, de alta calidad / High quality, durable chain end buffer

NEW 2022



Engranaje actualizado / Updated gearbox

NEW 2022



Bolsa de cadena actualizada / Updated chain bucket



Premium Polipasto Eléctrico de Cadena DEH / **Premium** Electric Chain Hoist DEH

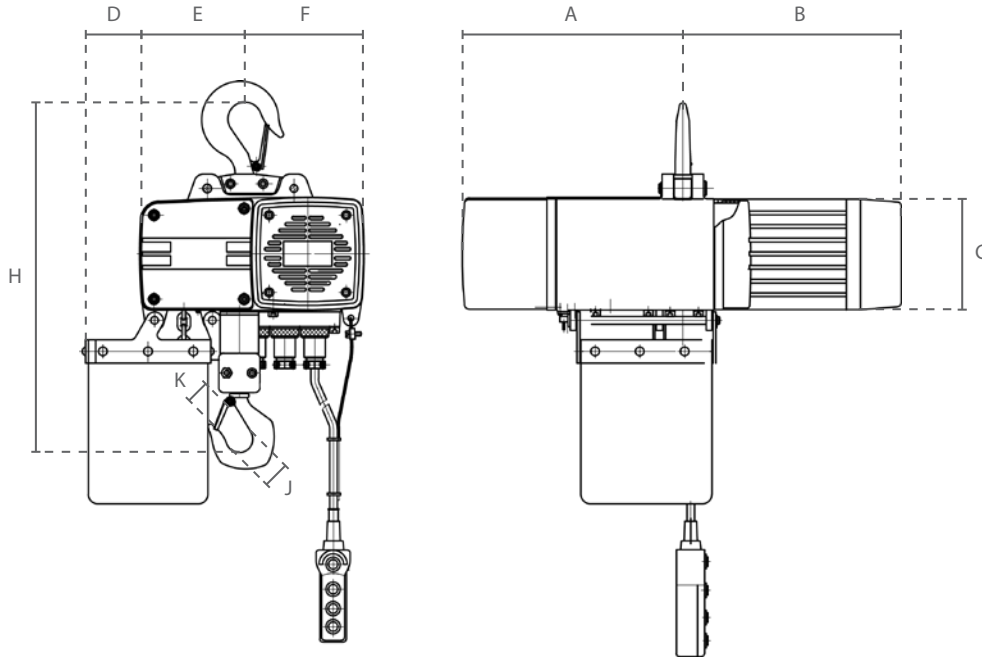

Dimensiones / Dimensions									
Código de artículo Article code	A	B	C	D	E	F	H	J	K
DH.0.DEH.001253	203	231	115	57	109	124	320	40	26
DH.0.DEH.002503	203	231	115	57	109	124	320	40	26
DH.0.DEH.00503	233	209	165	62	118	162	400	40	26
DH.0.DEH.01003	260	247	175	67	128	187	450	45	32
DH.0.DEH.02003	260	247	175	89	128	187	520	53	38

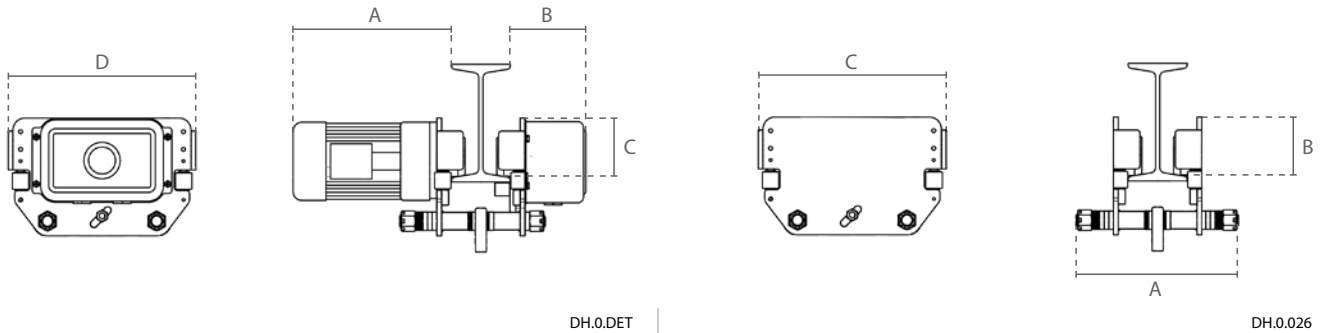

Especificaciones / Specifications					Dimensiones / Dimensions			
Código de artículo Article code	Capacidad Capacity	Radio mín. Min. radius	Diámetro de la rueda Wheel diameter	Peso neto Net weight	A	B	C	D
	ton	m	mm	kg				
DH.0.DET.0122	0.125	2.5	68	31	336	130	97	340
DH.0.DET.0252	0.25	2.5	68	31	336	130	97	340
DH.0.DET.0502	0.5	2.5	68	33	336	130	97	340
DH.0.DET.1002	1	2.5	68	33	336	132	97	340
DH.0.DET.2002	2	2.5	75	40	338	132	113	340

Especificaciones / Specifications					Dimensiones / Dimensions		
Código de artículo Article code	Capacidad Capacity	Radio mín. Min. radius	Diámetro de la rueda Wheel diameter	Peso neto Net weight	A	B	C
	ton	m	mm	kg			
DH.0.02600125	0.125	2.5	68	22	424	75	270
DH.0.02600250	0.25	2.5	68	22	424	75	270
DH.0.02600500	0.5	2.5	68	22	424	75	270
DH.0.02601000	1	2.5	68	22	424	75	270
DH.0.02602000	2	2.5	75	22	424	75	270